

# MAROLO

## E-LIFT

### LIFT 1200 ZL

#### USABLE WITH



#### CAPACITY



#### ENERGY

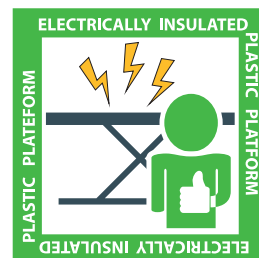

- Insulated platform **1** = no electric shock
- Pneumatic energy = no double electric shock
- Insulated wheel clamp \* E-MotoFixe **2** (ref. 807400)
- Rear gate **3**
- Automatic & large access ramp **4**
- Automatic safety **5**
- Insulated and removable stand plates **6** (ref. 807500)
- Storage for tools, parts ... **7**

E-Lift must be connected to earth of the building with appropriated electric wire

\* The use of E-Motofixe is strongly recommended to preserve the E-Lift

# E-LIFT

**MADE IN FRANCE**

**CE CERTIFIED**



**MAROLO E-LIFT**

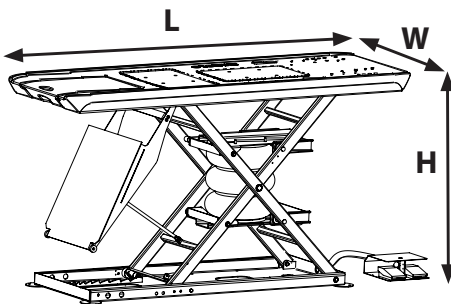

## SPECIFICATIONS

MODEL	Ref.	H	L	W	CAPACITY	ENERGY	WEIGHT
1200 ZL	807100	1200 mm	2300 mm	750 mm	400 Kg	Pneumatic 8 Bar mini	270 Kg

# WWW.MAROLOTEST.COM

## How to order?



Lucie



Email : [contact@marolotest.com](mailto:contact@marolotest.com)

Tel : +33 (0)2 41 29 29 29



Manfred



Email : [mmueller@marolotest.com](mailto:mmueller@marolotest.com)

Tel : +49(0) 173 4817732



Alexandre



Email : [aponsich@marolotest.com](mailto:aponsich@marolotest.com)

Tel : +34(0) 660 605 106

**MAROLO**

Boulevard du Cormier - Parc d'activités du Cormier B.P. 20753 - 49307 CHOLET cedex - FRANCE

Tél. +33 (0)2 41 29 29 29 / Fax : +33 (0)2 41 29 29 30 / Email : [contact@marolotest.com](mailto:contact@marolotest.com) - Web : [www.marolotest.com](http://www.marolotest.com)